

OWNER'S MANUAL

**MODEL: G380PU
G380PU-1**

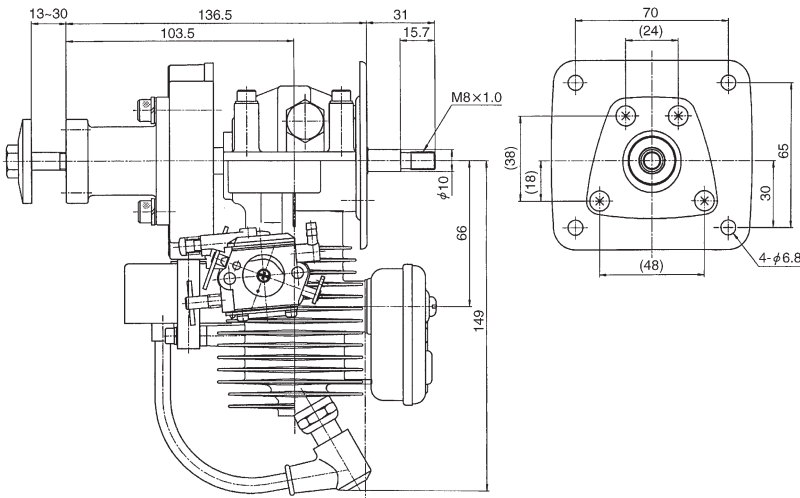

⚠ WARNING ⚠

- Do not modify any parts of the engine.
- This engine is designed to be used to Radio controlled products.
- In case any modification by customer, ZENOAH shall not bear any responsibility from the damage caused by such modification.
- Keep ignition system well maintained.

⚠ 警告 ⚠

- この製品はラジオコントロール飛行機用に設計されています。
- 改造、組み替えされて使用された場合当社は一切の責任を負いません。
- 特に電装品は常に点検、整備してご使用ください。

1. Safety Precautions

- This engine is designed for the model aircraft use. ZENOAH assumes no responsibility for those engines that are modified or used for any other applications.
- This Manual describes the engine part only. For its mounting to the aircraft and its control, see instructions described in the manual of the aircraft.
- Check the propeller every time before starting the engine, and replace it with a new one if it is damaged.
- When the propeller hits something in operation, immediately stop the engine and check it.
- Check the flywheel, and replace it with a new one if it is damaged.
- Never modify the flywheel.
- Use the ZENOAH genuine parts for replacement.
- When the vibration is abnormal, stop the engine and check the entire unit for possible damage or loose fasteners.
- Mixing the gas and 2-cycle engine oil and filling it up are to be done in a well-ventilated place.
- Never run the engine in a place of poor ventilation, as exhaust fumes contain harmful carbon monoxide.

2. Fuel

Mix unleaded gasoline and 2-stroke oil in the ratio of 25 ~ 40:1.

[NOTE]

1. Be sure to use a gasoline-resistant fuel piping. (Do not use any silicon rubber tube).
2. Never use any alcohol fuel or alcohol-added fuel, or the rubber part in the carburetor will be damaged.

3. Operation

Starting Engine

1. Fill the fuel and fix to the aircraft body firmly.
2. Close the choke and set the throttle to one third open.

[NOTE]

If the choke is closed too much, it may dampen the spark plug and it may cause starting failure.

3. Turn the propeller slowly counterclockwise until it is resisted, and then powerfully. When turning it manually, use all the fingers except the thumb. Turn it at proper intervals.

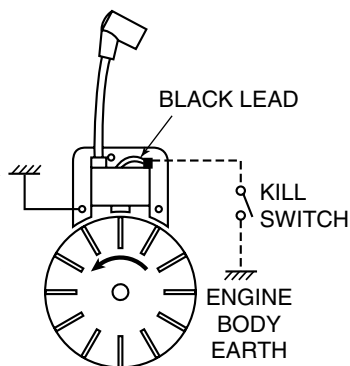

4. When engine first fires, open the choke and turn the propeller again in the same manner.
5. When the engine is started, warm it up for 2 to 3 minutes at low speed.

Stopping Engine

Ground the black wire from the source coil to the engine, and the engine will stop.

4. Carburetor Adjustment

The carburetor comes with a standard setting.

This setting is for optimum performance under the barometric pressure and climactic conditions at the factory.

Therefore, the carburetor should be readjusted with a load applied (with the propeller mounted) after the engine having been warmed up.

[NOTE]

1. Adjustment standards :

LOW SPEED NEEDLE : $1 \pm \frac{1}{4}$ turns open

HIGH SPEED NEEDLE : $1\frac{1}{2} \pm \frac{1}{4}$ turns open

2. **IDLE SCREW** - Turn clockwise to increase the idling rpm.
3. **LOW SPEED NEEDLE** - This needle controls fuel flow in the low rpm range. Turning clockwise makes the fuel lean. Turning counterclockwise makes the fuel rich.
4. **HIGH SPEED NEEDLE** - This needle controls fuel flow in the high rpm range. Turning clockwise makes the fuel lean and the reverse makes it rich. Set the needle $\frac{1}{4}$ turns open from a position where the peak rpm is obtained on the ground.
5. Do not overtighten the needles.
6. Warm up the engine before adjusting the carburetor.
7. Make sure to stop the engine while adjusting the carburetor.

5. Daily Inspection

- Check if screws and bolts are firmly tightened.
- Check if there is any fuel leakage.
- Check if there is any damage (crack or deformation).
- Check if the fuel line is clogged.
- Check if the spark plug and the muffler are contaminated.

Table of Tightening Torque

Applicable positions and Part Names	Illustration index No.	Tightening Torque
1. Crankcase fixing bolt	14	50 ~ 80 kg-cm, 3.6 ~ 5.8 ft-lbs.
2. Flywheel fixing hub nut	30	150 ~ 190 kg-cm, 10.8 ~ 13.7 ft-lbs.
3. Muffler fixing bolt	12	40 ~ 50 kg-cm, 2.9 ~ 3.6 ft-lbs.
4. Ignition module fixing screw	43	20 ~ 25 kg-cm, 1.4 ~ 1.8 ft-lbs.
5. Insulator fixing screw	4	30 ~ 40 kg-cm, 2.2 ~ 2.9 ft-lbs.
6. Carburetor fixing screw	45	30 ~ 40 kg-cm, 2.2 ~ 2.9 ft-lbs.
7. Mount plate fixing screw	47	30 ~ 40 kg-cm, 2.2 ~ 2.9 ft-lbs.
8. Spark plug	42	150 ~ 180 kg-cm, 10.8 ~ 13.0 ft-lbs.

WARNING !

When the engine is not in use, take great care in casually flipping the prop as you might do in checking compression or for adequate lubrication in engine. These ignition engines will fire and start with just one weak flip. Broken arms have already resulted from just such an unexpected experience.

6. Specifications

Model	G380PU · G380PU-1
Type	Single cylinder gasoline engine, 2-stroke air cooled
Displacement.....	37.4cc (2.28cu. in.)
Bore x Stroke.....	38mm x 33mm (1.496 in. x 1.299 in.)
Compression ratio	6.8 : 1
Fuel.....	Gasoline mix (mixture ratio gasoline to 2-stroke oil : 25 ~ 40 : 1)
Carburetor	WALBRO WT338
Ignition	Flywheel magneto (contact-less type)
Spark plug	CHAMPION RCJ7Y
Service engine speed.....	7000 ~ 9000rpm
Allowable engine speed (instantaneous)	12000rpm
sizes (L x W x H)	170 x 130 x 215mm (6.30 x 5.12 x 8.46 in.) (Length covers as far as the end of the hub nut.)
Weight	2.0kg (4.4 lbs)

Specifications are subject to change without notice.

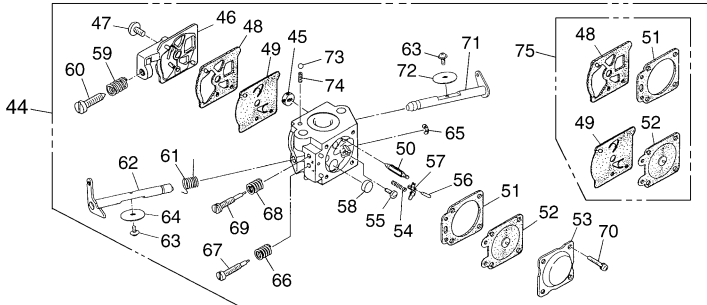

(Standard Accessory
for G380PU)

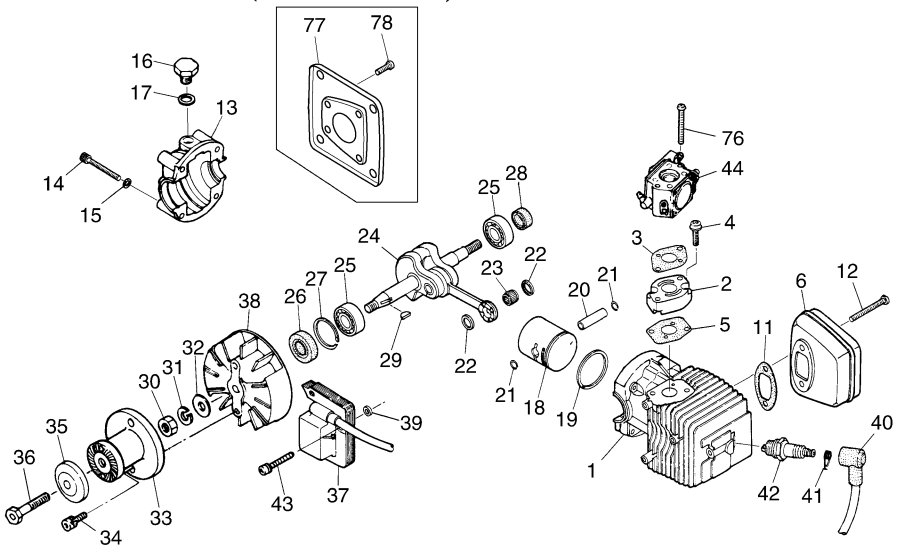

G380PU, G380PU-1

Index No.	Parts No.	Description	Q' ty /unit	Index No.	Parts No.	Description	Q' ty /unit
1	3378-12111	Cylinder	1	46	2630-81120	• Cover	1
2	3330-14111	Insulator	1	47	3310-81130	• Screw	1
3	3330-14121	Gasket	1	48	3304-81140	• Gasket	1
4	0260-20520	Screw	2	49	1172-81150	• Diaphragm	1
5	3330-14132	Gasket	1	50	3356-81310	• Valve	1
6	2609-15001	Muffler assy	1	51	2850-81290	• Gasket	1
				52	3310-81260	• Diaphragm	1
11	2841-15210	Gasket	1	53	3310-81280	• Cover	1
12	3330-15220	Bolt	2	54	2670-81270	• Spring	1
13	3378-21110	Crankcase	1	55	3310-81240	• Screw	1
14	01252-30540	Bolt	4	56	3310-81250	• Pin	1
15	0292-20510	Washer	4	57	3310-81230	• Lever	1
16	3120-13510	Plug	1	58	1480-81420	• Plug	1
17	3130-13520	Gasket	1	59	3350-81380	• Spring	1
18	3340-41113	Piston	1	60	2630-81330	• Screw	1
19	3340-41211	Ring	1	61	2670-81410	• Spring	1
20	3304-41310	Pin	1	62	2609-81370	• Shaft	1
21	3310-41320	Ring (Circlip)	2	63	2880-81470	• Screw	2
22	1650-41510	Washer	2	64	3356-81340	• Valve	1
23	3310-41410	Bearing	1	65	1148-81390	• Ring	1
24	3378-42000	Crankshaft comp.	1	66	1491-81160	• Spring	1
25	06030-06201	Bearing	2	67	2609-81170	• Needle	1
26	1650-21220	Seal	1	68	3080-81320	• Spring	1
27	04065-03212	Ring	1	69	2609-81330	• Needle	1
28	2169-21210	Seal	1	70	3310-81351	• Screw	4
29	1260-43240	Key	1	71	2813-81460	• Shaft	1
30	1140-43231	Nut	1	72	2670-81450	• Valve	1
31	0290-20820	Washer	1	73	3350-81220	• Ball	1
32	01641-20812	Washer	1	74	3350-81350	• Spring	1
33	2609-51110	Hub	1	75	T2100-06020	• Gasket kit	1
34	3544-11510	Bolt	2	76	0260-10540	Screw	2
35	1145-43290	Washer	1	77	3378-85111	Mount	1
36	2609-51411	Bolt	1	78	3310-31720	Screw	4
37	3378-71110	Module	1			} for G380PU	
38	2609-71210	Rotor	1				
39	1260-71261	Spacer	3				
40	1400-72111	Cap	1				
41	1400-72121	Spring	1				
42	3699-90032-10	Spark plug	1				
43	3310-72150	Bolt	3				
44	2609-81000	Carburetor assy (WT338)	1				
45	3306-81380	• Screen	1				

8. Warranty

● **Scope of Application**

This warranty applies only to the engines and parts manufactured by ZENOAH and sold directly or through distributors.

● **Limit of Warranty**

This warranty shall apply only to trouble resulting from material defects and inferior assemblies that ZENOAH acknowledges.

● **Method and Limit of Compensation**

- 1) Repair or replacement through the distributor, etc.
- 2) ZENOAH and its distributors shall not provide compensation for incidental loss to engine purchasers resulting from trouble.

● **Term of Warranty**

The term of warranty shall be three (3) months from the date of purchase, within one year from the date of manufacture.

● **The warranty shall not cover the following, even if occurring during the term of warranty:**

- 1) Any faults, failures caused from neglect of this OWNER'S MANUAL for proper operation and maintenance.
- 2) Dismantled or modified engines and parts.
- 3) Expendable parts.
- 4) Trouble resulting from submersion in water, from fire or from other natural disasters and calamities.
- 5) Engines installed with parts that are not genuine.



Head Office : 1-9 Minamidai, Kawagoe-city, Saitama, 350-1165 Japan

Phone: (+81)49-243-1115 Fax: (+81)49-243-7197